

PRODUCT DATASHEET

ENDURA Classic Pipe 50cm Post E27 Amber

ENDURA® CLASSIC PIPE | Contemporary aluminium luminaires with amber colored glass diffusor



Areas of application

- Building facades
- Entrance lighting
- Patios, balconies
- Pathway lighting
- Driveways

Product benefits

- High flexibility in the choice of the light source thanks to E27 base
- Easy and quick installation

Product features

- Direct illumination
- Light cover material: glass
- Light cover appearance: amber
- Housing material: aluminum
- Housing color: RAL 7016
- Type of protection: IP44



TECHNICAL DATA

Electrical data

Nominal voltage	220...240 V
Mains frequency	50...60 Hz
Protection class	I
Operating mode	Mains voltage

Photometrical data

Photobiological safety group acc. to EN62778	RG1
Photobiological safety group acc. to EN62471	RG0

Dimensions & Weight

Diameter	135.00 mm
Height	500.00 mm
Product weight	1015.00 g

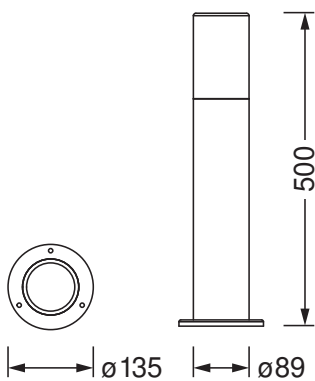

Materials & Colors

Product color	Dark gray
Housing color	Dark gray
Body material	Stainless steel
Cover material	Glass
Mercury content	0.0 mg

Application & Mounting

Type of connection	Terminal, 3-Pole (L, N, PE)
Type of protection	IP44
Protection class IK (shock resistance)	IK03
Dimmable	No
Mounting type	Surface
Mounting location	Ground
Application environment	Outdoor
With light source	No
Holder designation	E27

Emergency lighting

Type of emergency light operation	Non-maintained
Luminous flux in maintained operation mode	-
Luminous flux in emergency operation mode	-

Certificates & Standards

Standards	CE / EAC / UKCA
-----------	-----------------



Additional product data

Product remark	Maximum bulb wattage: 25 W
Number of illuminants	1

EQUIPMENT / ACCESSORIES

- Complete mounting and connecting accessories included
- No light sources included

DOWNLOAD DATA

Documents and certificates	
	User instruction
	Declarations Of Conformity CE
	Declarations Of Conformity UKCA

LOGISTICAL DATA

Product code	Packaging unit (Pieces/Unit)	Dimensions (length x width x height)	Gross weight	Volume
4058075554238	Folding box 1	145 mm x 145 mm x 540 mm	1222.00 g	11.35 dm ³
4058075554245	Shipping box 2	560 mm x 310 mm x 165 mm	3085.00 g	28.64 dm ³

The mentioned product code describes the smallest quantity unit which can be ordered. One shipping unit can contain one or more single products. When placing an order, for the quantity please enter single or multiples of a shipping unit.

DISCLAIMER

Subject to change without notice. Errors and omission excepted. Always make sure to use the most recent release.